



-power in control



POWER & CONTROL TECHNOLOGY: GAS CONTROL TECHNOLOGY

Control All Types, Makes and Sizes

Efficiently and regardless if your gas is bio, natural, landfill or other, our control solutions will enable you to convert it into energy like no other systems. The size of your application is not an issue for us. Nor is the type and make of your gas engine or turbine.

Costs Down – Value Up

DEIF solutions are designed to optimise operation and reduce gas consumption. Your expenses will drop from day one. You will always be backed by a team of experienced service and support engineers.

You Name it – We Develop it

DEIF's standard controllers are extremely flexible and will accommodate most of your needs. But we are also happy to develop completely unique solutions designed exclusively for your specific application. The solutions are subject to continuous review and approval by our quality-conscious customers.

Retrofits are one of our core competencies. Replacing existing OEM genset controllers with 1:1 conversions or according to customer specifications, we can have an entire system up and running in just a few days.



Hans Thomsen
Global Sales Manager
hat@deif.com

Gas Applications Include:

Biogas



Landfill Gas



Natural Gas



Modular and Reliable

- ✓ Free of charge SCADA for Delomatic 400 Gas
- ✓ Controllers for all power ranges, 10 kW and up
- ✓ All necessary controls within one unit
- ✓ Interfaces directly to ignition and mixer systems

Full Gas Engine Control

All-in-one Solution

A Complete Controller Range

From Basic to Complex Quality Solutions

▲ Complexity

GPU-3 Gas

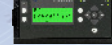

GPC-3 Gas



AGC-4 Gas



DM 400 Gas

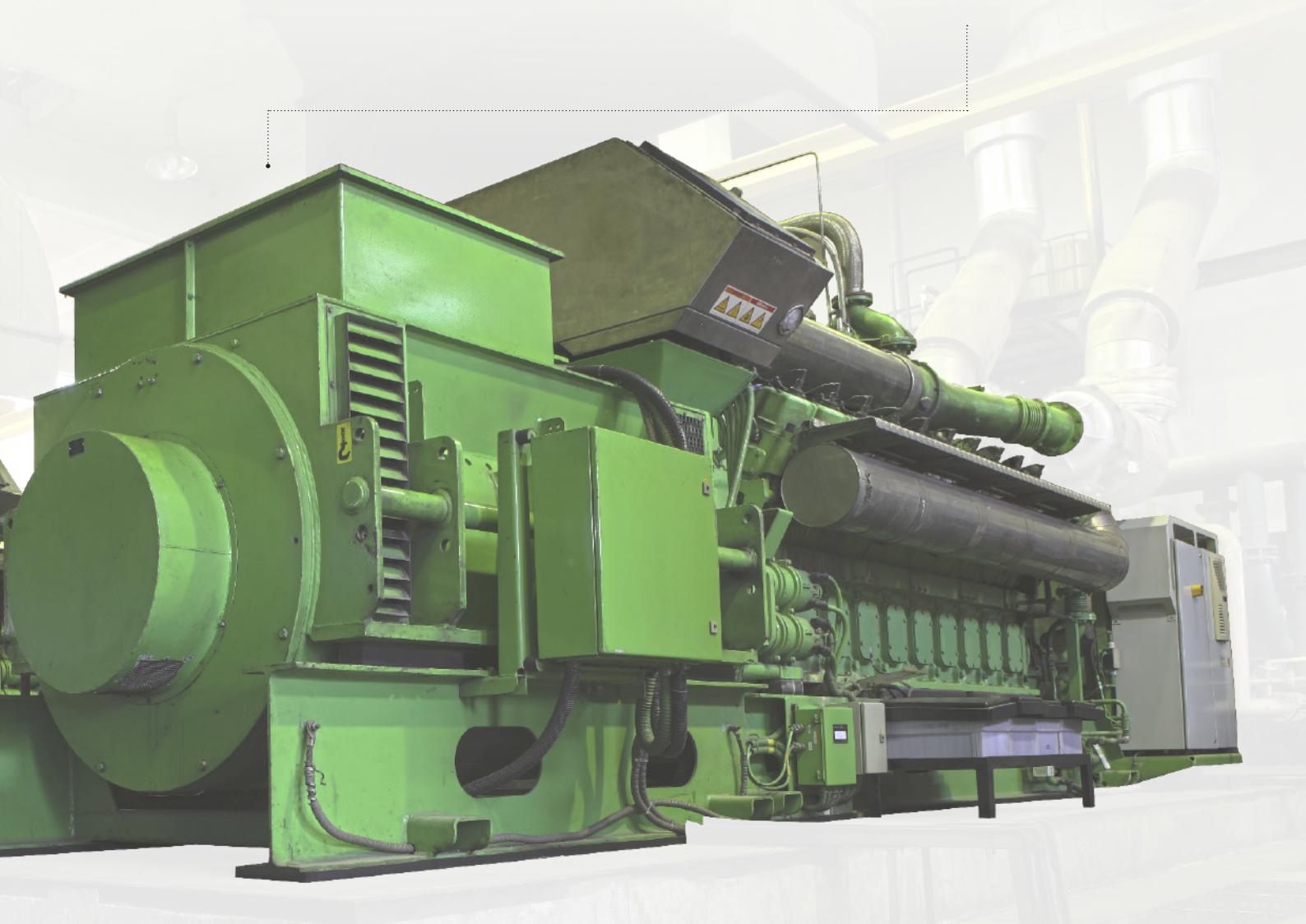

Best in Class

- ✓ 3 controllers to fit all applications
- ✓ Fully automated for unmanned operation
- ✓ Operator-friendly
- ✓ Remote control from central control room

Cut Your Cost

- ✓ Gas quality-optimised running
- ✓ Cut in personnel cost
- ✓ Power management
- ✓ Free of charge PC programming tool



Power in Control

The following pages feature a selection of case studies for a number of different applications that successfully run DEIF units and solutions.

DEIF has become a preferred control solution supplier to some of the biggest operators in the market, not just because of our innovative, safe and reliable technology but because of our commitment in guiding you through all phases of your project, from specification to installation or configuration. DEIF's flexible product platform covers the full range of application possibilities.

Most customers are able to install and commission our standard products working from data sheets only. But in cases of doubt, DEIF's far-reaching network of sales and competence centres, distributors, customer care teams, and technical support teams is available to assist you and ensure you invest in and implement the best controller for your application.

DEIF realises how space is always in demand. Saving you time and cost, our standard controllers require limited room for mounting and installation in switchboard cabinets.

Basic installation information can be found in the product quick start guide, and application setup is made easy with DEIF's Utility Software.

For greater detail, we refer you to the product installation instructions, just as you are invited to attend training courses on how to install and operate DEIF's standard controllers.

The entire CHP was commissioned and operating within 24 hours...

The pretty Norfolk village of Wighton is the site of family-owned Copys Green Farm with 100 dairy cows and 500 acres of farmed land, the majority producing maize and fodder beet. Run by Dr Stephen Temple, who spent 23 years lecturing and doing research in Agricultural Engineering in Malawi before returning to Norfolk, Copys Green Farm's traditional English setting belies its progressive initiative.

Awarded 2010 Green Energy Farmer of the Year for his vision and commitment to green farming, Temple has successfully invested in one of the few Anaerobic Digestion systems (AD) in England: Cattle manure and silage from the dairy farm and whey from the cheese-making enterprise are fed into the facility, producing biogas that can be used for heat and electricity production.



With surplus energy sold to the grid, the by-product "digestate" used as a free fertiliser replacement and the much-reduced cost of disposing manure, silage and whey, going green has also turned out to make good business sense.

But crucially, because of operational problems, the original AD's Combined Heat and Power system (CHP) at Copys Green was unable to achieve grid connection until June 2010. According to Stephen Temple, this was a major setback as the return from the sale of electricity and the benefit of not having to buy in electricity is considerable. The installation cost for the system came to £750,000. Achieving stable operation was paramount to reaching his eight-year target for return on investment.

Starting again, Temple spent a good amount of time looking at as many different systems as possible, finally deciding to go with Austrian IET supplying a genset with DEIF's acclaimed gas control solution, Delomatic 400 Bio (DM 400 Bio). Temple chose DEIF because of the proven nature of the company's technology and the fast delivery time.

In line with our standards, DEIF promised delivery in approximately eight weeks, faster than any other offers Dr Temple received. A delay of as little as two weeks would have meant a loss of exported electricity income of £7,500, plus the additional cost of the imported power consumed.

Having studied the particulars, DEIF delivered the proposed scheme at the end of January 2011. Because DEIF's DM 400 Gas is so simple to install, the entire CHP system was commissioned within a 24-hour period and operating satisfactorily almost immediately. Since then, there have been no major issues and the operational availability of the system is very high. With an uptime of 99%, the system achieves 85% of permissible electrical export capacity: generated electricity meets all on-site demands plus export to grid of 130 kWe. Feed-in tariff earns approximately £500 per day.

Copys Green Farm: Norfolk, United Kingdom

Vision and Commitment to Green Farming

Data

- ✓ JF Temple & Son Ltd – Copys Green Farm, Norfolk
- ✓ Digester Tank 800 m³, residence time 40 to 50 days at 37 to 42°C
- ✓ Gas Holder capacity 350 m³, at low pressure 20 mbar
- ✓ Methane content of gas managed to a constant value between 50 to 55%
- ✓ Gas utilised in MAN 6 cylinder-powered CHP scheme of 170 kW_e and 200 kW_t
- ✓ Controlled by DEIF DM 400 Bio
- ✓ Heat utilised for maintaining digester temperature, heating farm house, cheese-making processes, dairy wash water, warm drinking water for cows and crop drying.
- ✓ Cost saving enhanced by not having to pay to dispose of manure, silage or whey as all is used in the digester.

Product

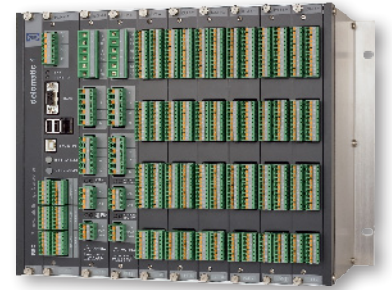

Integrated Systems, DM 400 Gas

Diagram From Case

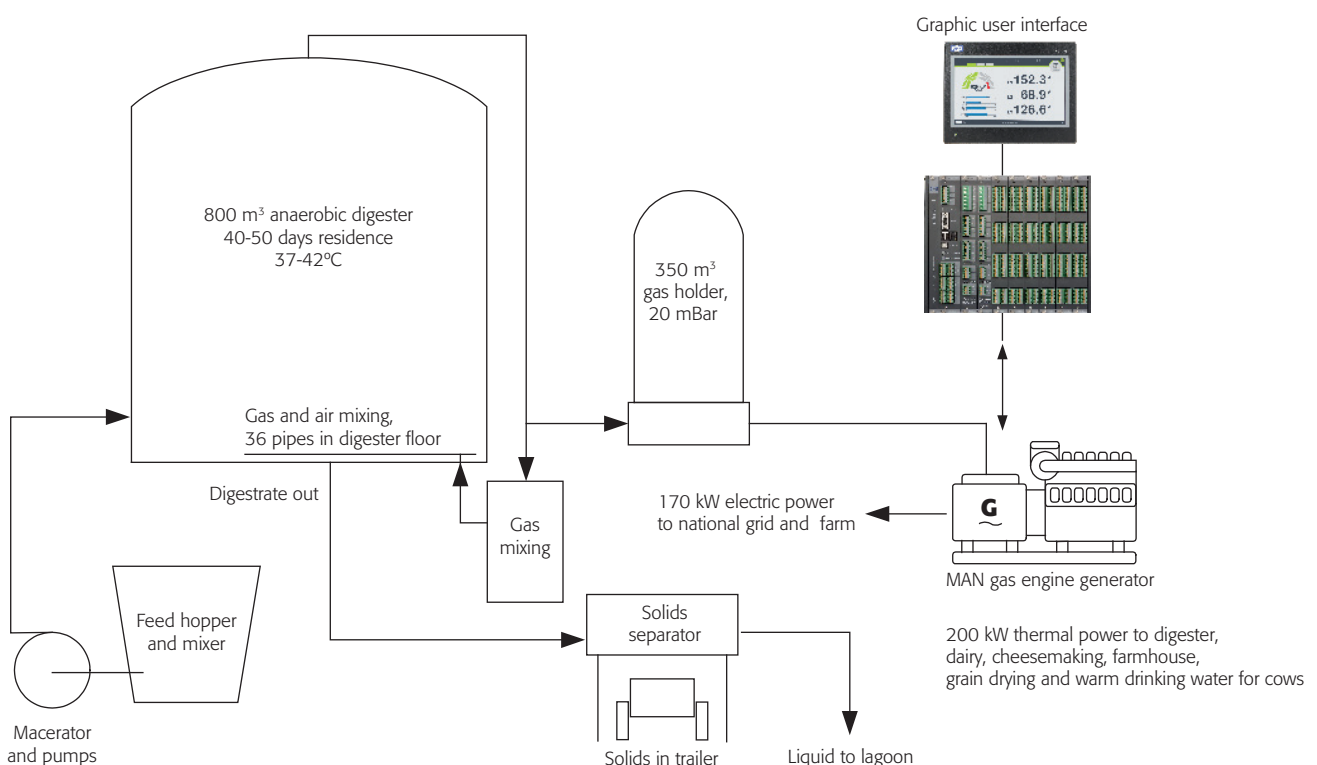

Landfill Gas Case Study

The positive experiences from São João make future biogas projects more likely...

In the São Paulo district of São João, you can see a system of plastic pipes worth gold running along the sides of a putrid mountain of waste more than 150 meters high.

The pipes channel filtered landfill gas for the generators at a nearby 25 MW gas power plant. Produced by the landfill waste and collected in a number of gas wells distributed across the 80 hectare 500 ft. landfill areas, the biogas is transported from the wells through the pipes to the on-site gas treatment facility located on the top of the landfill mountain. Here the foul-smelling gas is cooled and the vapour that would otherwise clog the gas pipes and damage the machines later in the treatment process is removed.



Since the plant began operation, it has cut millions of tonnes worth of methane emissions. The reductions have generated substantial profits to the owner who sells CO₂ quotas and invests the profits in new biogas and power plants. The Brazilian company has seemingly struck gold with its biogas project.

Equipped with 16 × 1.54 MW gensets and Caterpillar G3520C engines supplied by Sotreq, Brazil's biggest Caterpillar dealer, the plant features a DEIF power control system of AGC Automatic Genset Controllers.

Sotreq chose the DEIF units for the project because of the DEIF solution's proven reliability, comprehensive levels of protection, simple operation and its fuel-efficiency.

Sotreq's Engineer Manager, Mauricio Garcia, thinks this project is a frontrunner for more to come.

"There are few biogas projects in Brazil," he says. "But the positive experiences from the São João project make the future construction of similar installations more likely." He also credits DEIF for part of the project's success. "The AGCs have been vital in ensuring optimum generator operation at all times and ultimately help us provide a more sustainable and reliable energy supply."

Data

- ✓ 16 generators, 1.54 MW each
- ✓ Fully automated power control
- ✓ Fully integrated generator control and protection
- ✓ Gas from waste mountains in Sao Paulo, Brazil
- ✓ Gas wells spread over 80 hectare
- ✓ Substantial savings in CO₂ emissions and income on selling CO₂ quotas

Product



Automatic Genset Controller, AGC-4 Gas

Diagram From Case

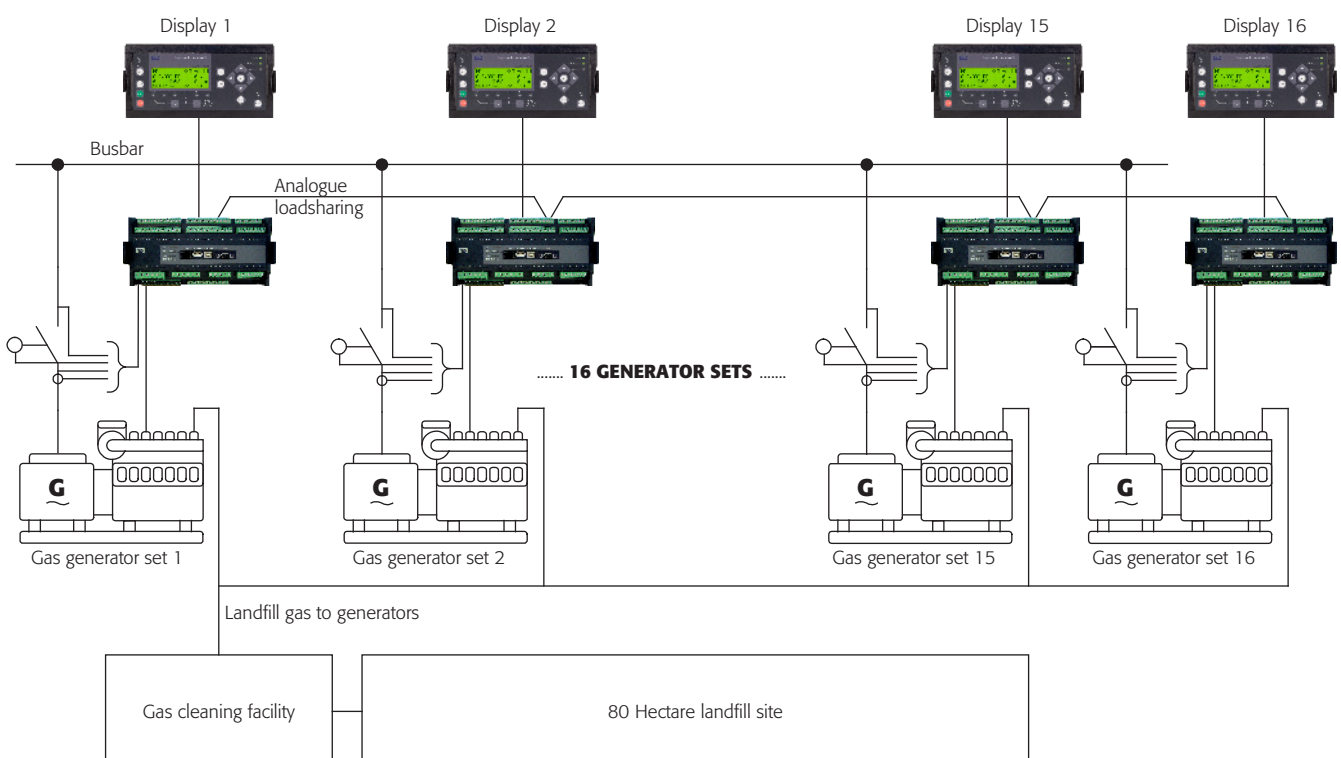

Refitting a gas engine control system can make good financial sense and be a green advantage...

Refitting an existing gas engine control system with DEIF's comprehensive and innovative Delomatic 400 Gas solution, DM 400 Gas, can make good financial sense and be a green advantage.

The gains are significant and tangible in the form of immediate improved engine performance and reduced emissions. The refitting has a short to medium term return on investment time, and in the longer perspective improved engine performance and a reduced need for servicing means a longer operation life for the generator.

A recent project in the Gabonese Republic's isolated wet forest region of the Middle-Ogooué saw DEIF replace the control systems of a group of hardworking Deutz engines at the Echira onshore and offshore oil field. Fuelled by the oil production wells' waste gas, the power generators provide electricity for 60 oil wells, injection compressors, separation heaters and other oil and gas critical processes.

With an output target set at 10.000 barrels of oil per day, production is dependent on the availability and stability of four Deutz type TBG 632 16 cylinder generator sets: three of the four engines must run 24/7 to generate the 7,000 to 8,000 kW needed for production.

After detailed pre-engineering work and emulation tests, DEIF supplied a complete DM4-Gas control system with multiple side components. DEIF also replaced the cubicle design and supplied and handled adaptation of the existing switchboard including on-site dismantling, mounting and wiring of the new system followed by comprehensive tests, commissioning and fine tuning.

The DEIF solution

Replacement work had to be done engine by engine without plant shutdown, safely managing the complex and critical transition phases with the two systems, TEM and DM 400 Gas, operating simultaneously.

Following the well-planned and flawlessly executed DEIF refit, the TBG 632 16 cylinder generators now use less gas to produce more power. The previous black-out risk has been eliminated and Load Sharing between three engines has been tested up to 2900 kW with a slow power deviation between engines at less than 200 kW and frequency fluctuating slowly around +/- 0.06 Hz.

The combination of two engines in Load Sharing and one engine in Fixed Power was tested up to 2800 kW as the fixed power setpoint, with the Load Sharing engines sharing 1500 kW each. Again, the frequency remained at +/- 0.06 Hz.



Echira Oil Field: Middle-Ogooué, Gabon

No Black-out Risk & Less Gas With More Output

Data

- ✓ Using bi-product gas from oil production facility
- ✓ Island load sharing between generators
- ✓ Retrofitted existing control system with DM 400 Gas and AKR 3
- ✓ Digital communication to existing ignition system
- ✓ Individual cylinder firing angle delay based on knocking sensing
- ✓ Possible power output per generator set increased from 2,900 kWe
- ✓ Direct control of gas mixer stepper motor
- ✓ Combustion chamber temperature-based gas mixer control

Product

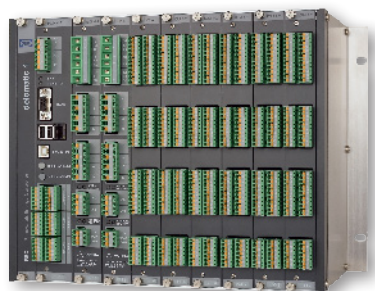

Integrated Systems, DM 400 Gas

Diagram From Case

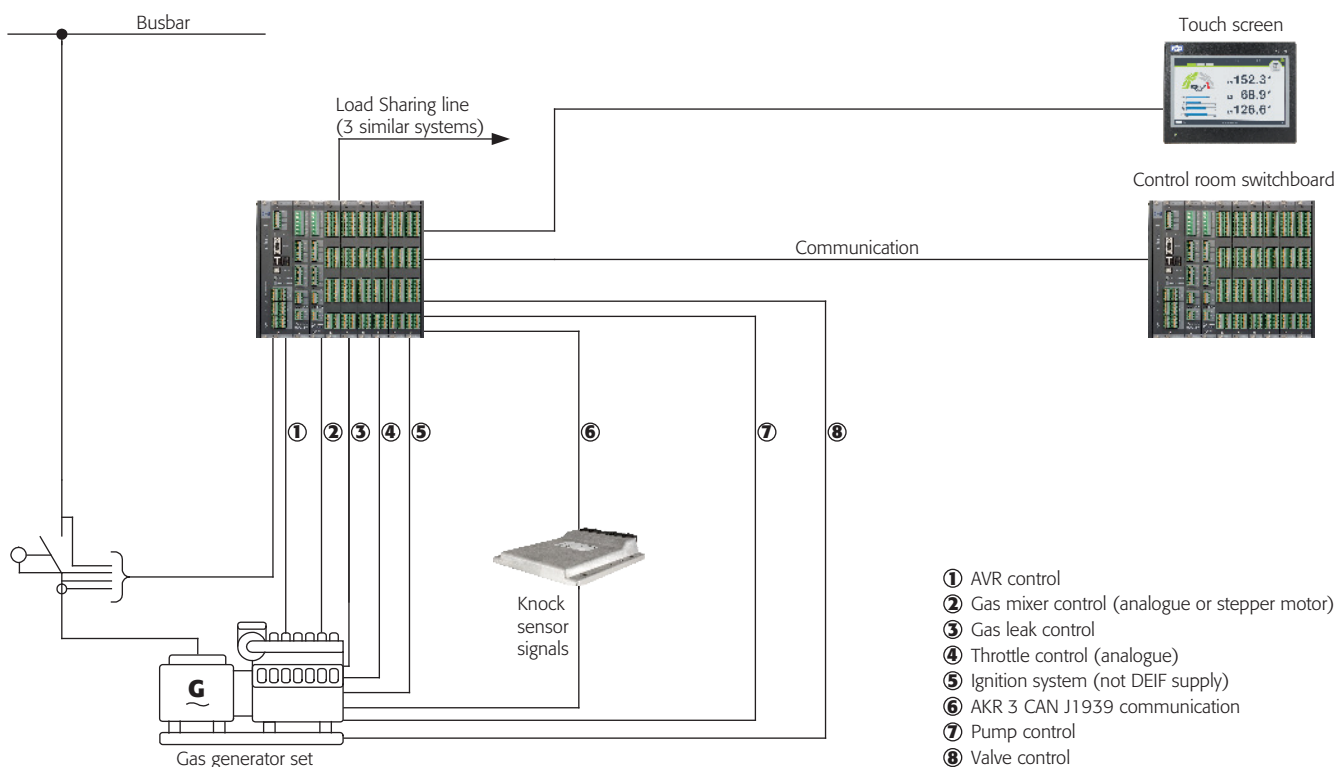

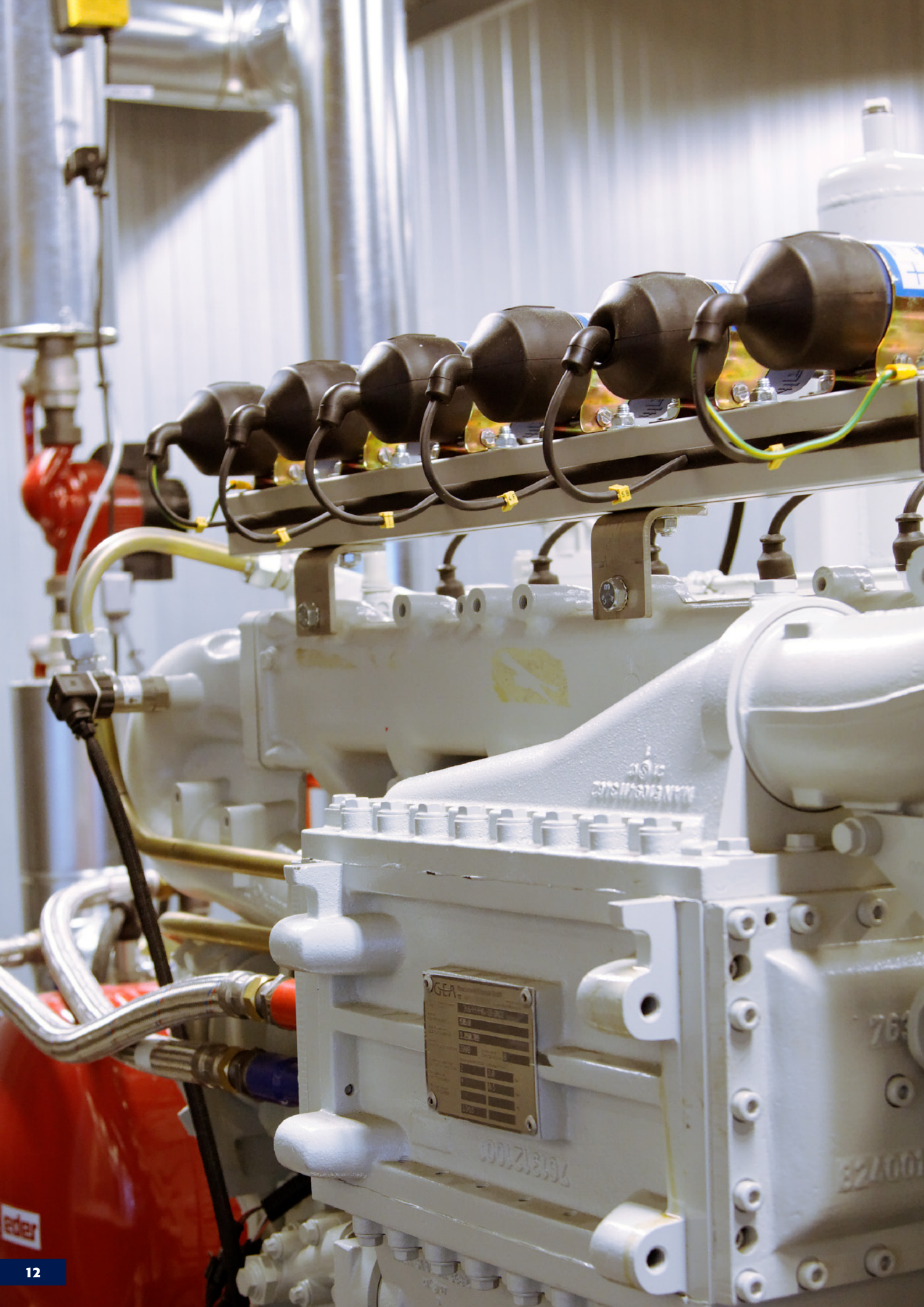

GEA
SPEZIFIKATIONEN
TABELLE 1
TABELLE 2
TABELLE 3
TABELLE 4
TABELLE 5
TABELLE 6
TABELLE 7
TABELLE 8
TABELLE 9
TABELLE 10

00171394

763
00171394

DEIF Gas Control Technology's market-leading gas controller solutions form a complete package in mains/generator/engine control and protection, suitable for integrated, customised solutions for all plant types and sizes.

DEIF's gas engine/genset controllers perform air/gas mixer control for various types of gas, including:

- Natural gas
- Landfill gas
- Bio gas
- Oil production waste gas
- Mine gas

DEIF solutions control the air/gas mix continuously to minimise emissions and to support stable engine performance, automatically de-rating engine power output in relation to methane content.

Award-winning and innovative, the controllers are some of the most comprehensive on the market today, ranging from cost-effective single and advanced multi-function controller platforms to units suitable for innovative, engineered solutions.

As a rule, DEIF's control concepts eliminate the need for external controllers and are user-friendly alternatives to standard controllers. Working with DEIF, you also benefit from the advantages of collaborating with one qualified supplier.

Ideal for retrofits, DEIF Gas Control Technology's control concept is cost-efficient and easy-to-implement all-in-one solution. The concept integrates functionalities such as synchronisation, controls (primary and secondary), protections, power management, auxiliary management and circuit management (water, gas, exhaust).

We also offer outstanding product quality, expert support engineers for standard support, consultant application engineers to check specifications, and project managers ready to assume responsibility for turnkey power management solutions.

Anti Knocking Regulator, AKR 3

Eliminate Knocking Tear and Wear on Your Gas Engine



DEIF's Anti Knocking Regulator AKR 3 is a state-of-the-art unit with knocking sensing based on single cylinder detection.

For correct knocking sensing, the AKR 3 uses digital FFT (Fast Fourier Transformation) to break down vibration data into individual frequencies and individual levels.

The use of FFT enables the AKR 3 to create an engine "image", which represents the frequencies and levels produced by the normal engine state, including gear wheel noise, bearing noise, normal combustion noise etc.

Filtering the "image" frequencies precisely highlights knocking frequencies for monitoring and taking action when needed.

In combination with the DM 400 Gas and communication to the ignition system, the AKR 3 offers the possibility to control the ignition-firing angle for each individual cylinder and thereby prevent knocking without having to decrease the genset power output.

AKR 3 Features

- ✓ Individual cylinder-knocking monitoring for up to 20 cylinders
- ✓ J1939 communication to controller
- ✓ Digital alarm outputs
- ✓ 4 to 20 mA overall knocking level output

AKR 3 Application Example

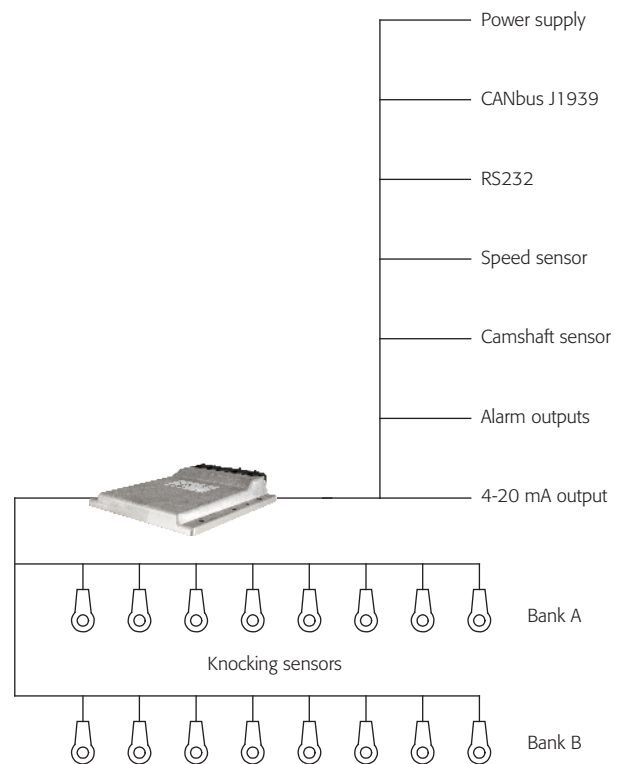

Generator Protection Unit, GPU-3 Gas

Full Generator Protection Package



Easy to operate and configure, DEIF's Generator Protection Unit GPU-3 Gas is an ideal controller for PLC-based power management systems.

The GPU-3 Gas offers comprehensive generator protection and synchronisation. Serial communication enables easy interfacing with PLCs, SCADA-systems and more, and the unit features all necessary 3-phase measuring circuits and displays all values and alarms on a quality LCD screen.

For start/stop and protection functionalities, add the GPU-3 Gas engine control option, an engine interface card with separate power supply and independent microprocessor. In cases of GPU-3 Gas main processor failure, the engine interface card will activate its back-up mode to ensure uninterrupted engine supervision and automatic engine shutdown in case of shutdown alarm.

With free software download and upgrade at www.deif.com, it is possible to customise the application to suit your needs exactly: dedicate specific functions or logic conditions to different inputs and outputs and tune all sequences according to your requirements.

GPU-3 Gas Features

- ✓ Generator/busbar protection
- ✓ Synchronisation
- ✓ Multiple display units and operator panels possible
- ✓ Engine control and communication

GPU-3 Gas Application Example

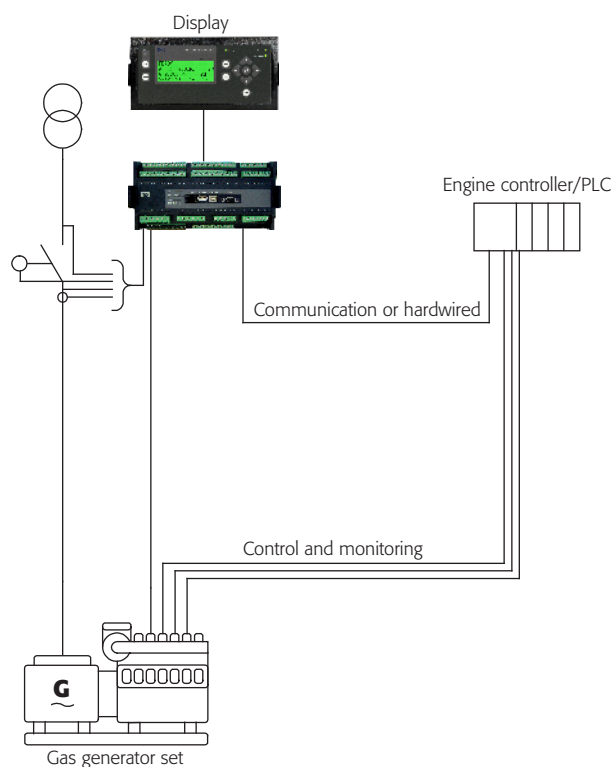

GPU-3 Gas Type Approvals



Generator Paralleling Controller, GPC-3 Gas

Designed for Integration with PLC Systems



The GPC-3 Gas is a highly versatile and compact generator paralleling controller designed for engineers who prefer to carry out application programming in a PLC.

A multi-function component, the GPC-3 Gas features protection, measurements, engine control and engine protection and communicates with all PLC and SCADA systems. Values and alarms are displayed on a large LCD screen.

Its simplicity and logic makes it the ideal controller for PLC-based power management systems.

The M-Logic configuration tool makes it possible to customise the application and dedicate specific functions or logic conditions to different inputs and outputs.

GPC-3 Gas is easily compatible with additional display units and Additional Operator Panels (AOPs) for remote control, supervision and status indication.

GPC-3 Gas Features

- ✓ Mains/Generator/Motor protection
- ✓ The unique M-Logic, a simple configuration tool
- ✓ Engine protection with backup on shutdown channels
- ✓ Governor and AVR control
- ✓ J1939 Engine Com/Mirrored Modbus/Profibus/TCP/IP
- ✓ Multiple display units and operator panels possible
- ✓ Additional Operator Protection (AOP)

GPC-3 Gas Application Example

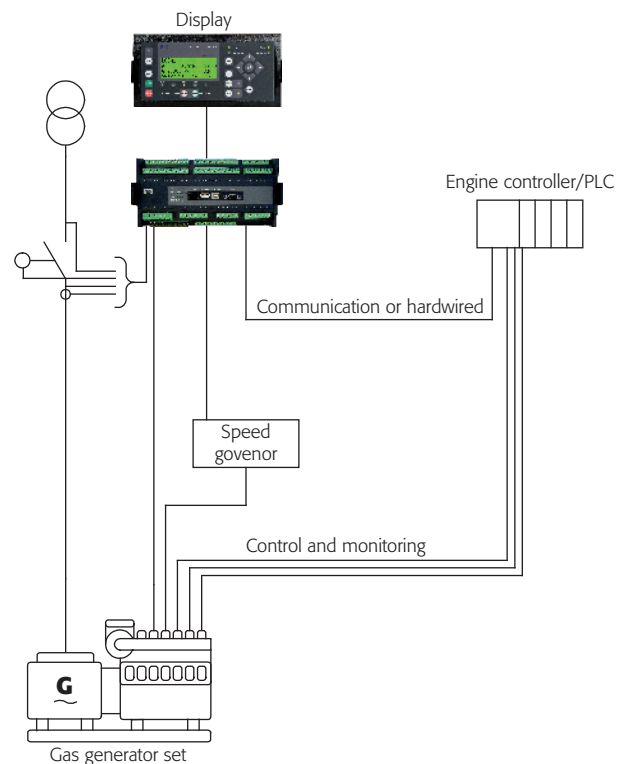

GPC-3 Gas Product Type Approvals



Automatic Genset Controller, AGC-4 Gas

Flexible Genset Control For Small and Medium-sized Gas CHP Plants



The AGC-4 Gas is a new flexible and scalable version of DEIF's award-winning AGC-4 controller developed to incorporate the standard model's wide feature range and dedicated engine controls and protections for gas systems.

When applied in connection with PLC-based CHP systems, the AGC-4 also controls MW-sized gas engine generator sets because the controller also features combined heat and power (CHP) functionality, this solution is an ideal choice for small and medium-sized gas-engine-driven CHP plants.

AGC-4 Gas supports serial communication protocols including Modbus (RS485, USB and TCP/IP) and profibus, enabling you to supervise and control your genset/plant from a remote location, minimise downtime and take immediate action on genset alarms and warnings.

Because the AGC-4 Gas comes with a series of hardware and software options, it is compatible with all types of engine/generator/CHP configurations.

AGC-4 Gas Features

- ✓ Gas engine start/stop sequences
- ✓ Gas mixer control (Lambda sensor or manifold p/T based)
- ✓ Parallel with grid operation
- ✓ Fixed power and Power Factor control
- ✓ Generator protections complying with international standards for parallel with grid protections
- ✓ Combined heat and power controls
- ✓ Heating circuit temperature-based power control
- ✓ Heating circuit temperature-based automatic start/stop
- ✓ CANbus J1939 communication to engine controller and AVRs

AGC-4 Gas Application Example

NOTE: Mains breaker control is optional

- ① AVR control
- ② Gas mixer control (analogue)
- ③ Gas leak control
- ④ Governor control (analogue)
- ⑤ Pump control/Valve control

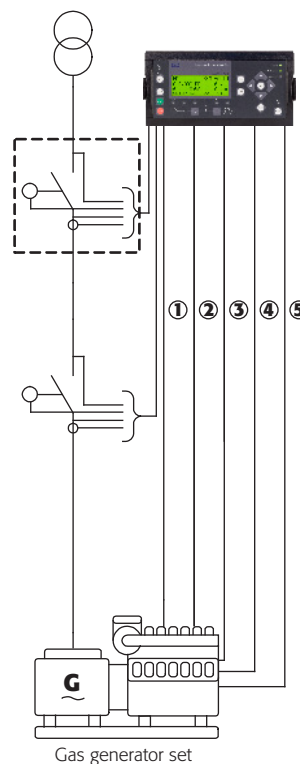

Integrated Systems, DM 400 Gas

Fully Automated Operation Without External Controllers

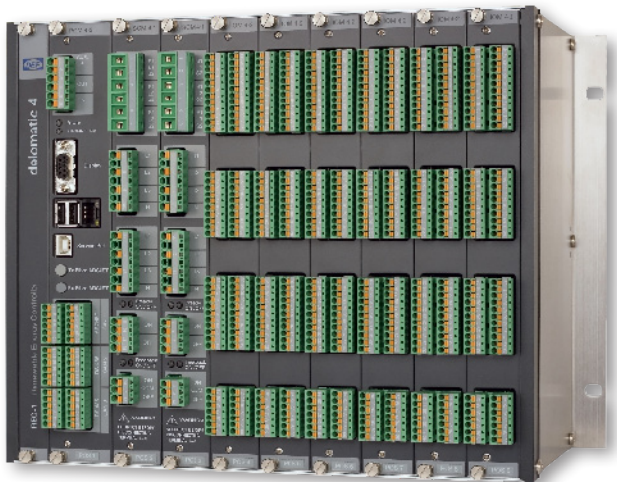

Top of the range, DEIF's advanced Delomatic 400 Gas (DM 400 Gas) system is a comprehensive and versatile platform for controlling and monitoring all aspects of gas-engine-driven gensets up to full Combined Heat and Power (CHP) control, including valves, pumps and fans etc.

The DM 400 Gas controller is designed as a modular process control. It covers the special requirements for decentralised energy production plants with respect to reliability, robustness, flexibility, and remote accessibility.

The DM 400 Gas is typically used for Gas CHPs with combustion engines and generators for fully automated (unmanned) operation.

The unique integration combined with support from our gas competence centre results in a simple and very user-friendly installation and day-to-day operation of your gas CHP.

DM 400 Gas' high integration level eliminates the need for external controllers, making it a very cost-efficient solution.

DM 400 Gas Features

- ✓ Gas engine and generator control, protection, synchronising and load sharing for both active and reactive power
- ✓ Mains protection including loss of mains detection
- ✓ Control of aux systems: gas mixture and gas circuit, air circuits/exhaust gas, cooling circuits/emergency coolers, heating circuits etc
- ✓ Emission control and communication to ignition system (Altronic CD200, Heinzmann Phlox 2 and others)
- ✓ PC touch interface including animated flow diagrams, log books and so on for easy supervision of the entire CHP (locally and remotely)

DM 400 Gas Application Example

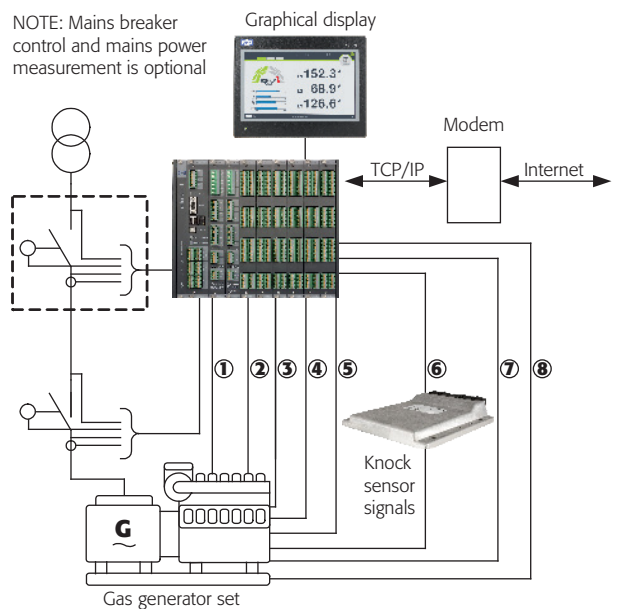

- | | |
|---|---------------------------------|
| ① AVR control | ⑤ Ignition system |
| ② Gas mixer control (analogue or stepper motor) | ⑥ AKR 3 CAN J1939 communication |
| ③ Gas leak control | ⑦ Pump control |
| ④ Throttle control (analogue) | ⑧ Valve control |

DM 400 Gas Type Approval



Integrated Systems, DM 400 Bio

Fully Automated Operation Without External Controllers

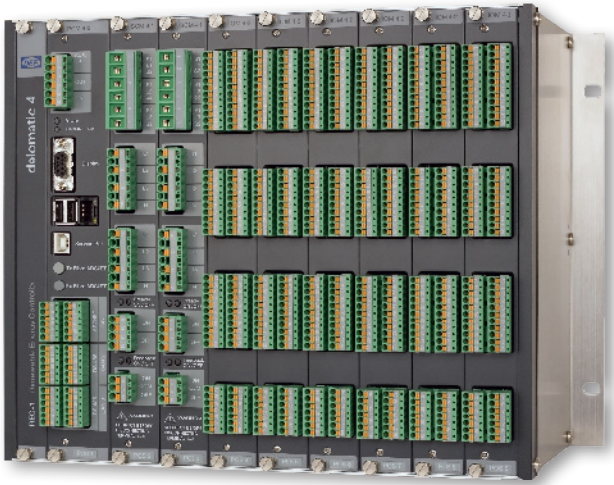

The DM 400 Bio controller is designed as a modular process control. It covers the special requirements for decentralised energy production plants with respect to reliability, robustness, flexibility, and remote accessibility.

The DM 400 Bio is typically used for vegetable oil/bio oil CHPs with combustion engines and generators for fully automated (unmanned) operation.

The unique integration combined with support from our project managers results in a simple and very user-friendly installation and day-to-day operation of your CHP.

DM 400 Bio's high integration level eliminates the need for external controllers, making it a very cost-efficient solution.

DM 400 Bio Features

- ✓ Bio oil engine and generator control, protection, synchronising and load sharing for both active and reactive power
- ✓ Mains protection including loss of mains detection
- ✓ Control of aux systems: fuel circuits/automatic change-over between fuel types, air circuits/exhaust gas, cooling circuits/emergency coolers etc
- ✓ Engine supervision including cylinder temperatures by direct thermocouple inputs
- ✓ PC touch interface including animated flow diagrams, log books, and so on for easy supervision of the entire CHP (locally and remotely)

DM 400 Bio Application Example

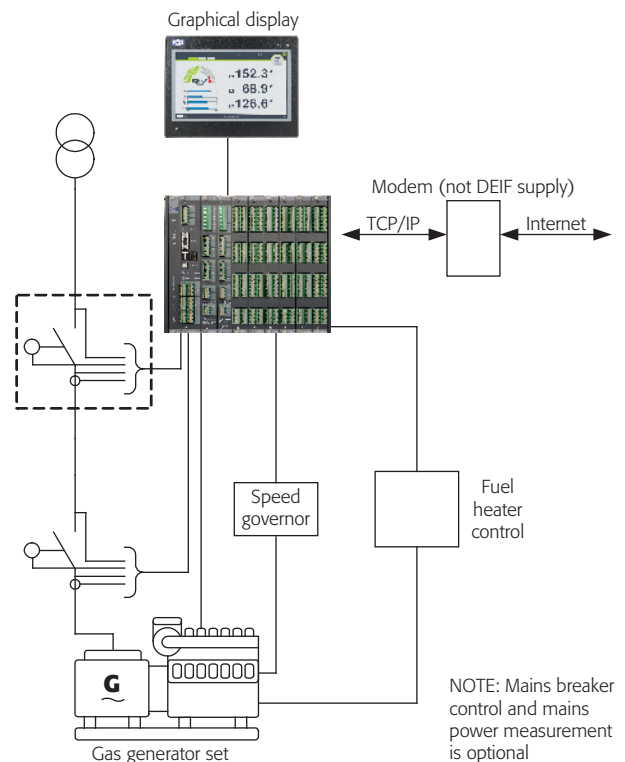

DM 400 Bio Type Approval



DEIF is a market leader with a proven record of more than 80 years of technological achievement and innovation in engine & genset controls, marine bridge instrumentation, switchboard instrumentation and renewable energy controls.

Our goal is to always bring a competitive edge to our customers' businesses by providing green, safe and reliable product lines with flexible features and first class service and support.

The DEIF Group is committed to maintaining and expanding its position as a trusted global supplier of quality solutions.



DEIF A/S · Frisenborgvej 33 · DK-7800 Skive · Tel.: +45 9614 9614 · Fax: +45 9614 9615 · info@deif.com · www.deif.com

POWER & CONTROL TECHNOLOGY: GAS CONTROL TECHNOLOGY

